

dimensioni in mm
dimensions shown in mm

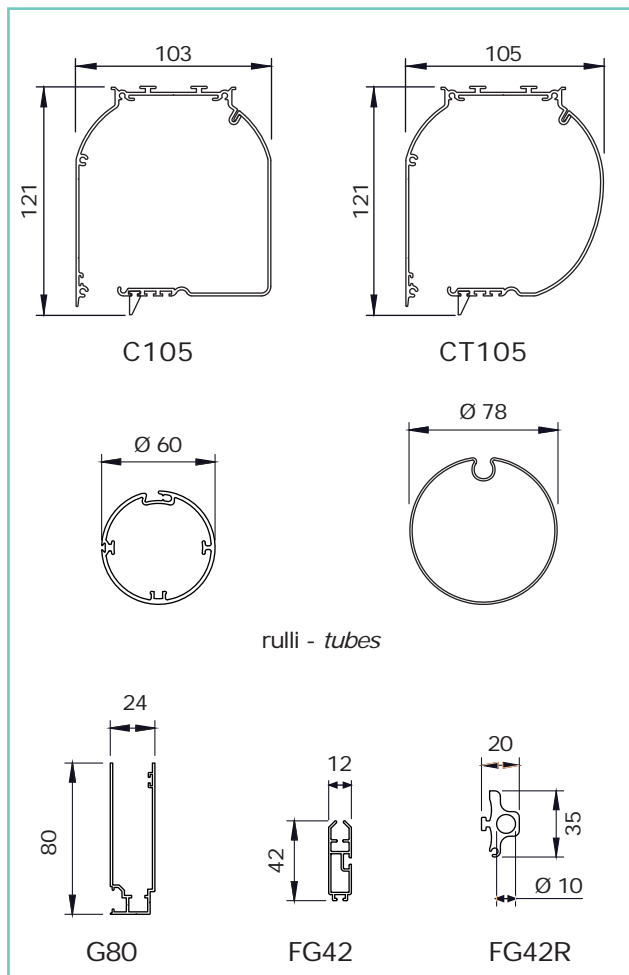

CARATTERISTICHE:

Tipo di applicazione: verticale

Ambiente di applicazione: esterno/interno

Cassonetto: C105/CT105 in alluminio estruso composto da una parte fissa e una mobile ispezionabile; coppie di testate in alluminio verniciato in tinta con il cassonetto.

A supplemento testate autoportanti in guida o testate per attacco laterale

Rullo di avvolgimento: Ø 60 mm in alluminio estruso oppure Ø 78 mm in acciaio zincato con ogiva per facilitare la manutenzione del telo

Guide: G80 in alluminio estruso comprensive di spazzolino; duplice funzione di trattenere il tessuto e chiudere gli spazi laterali per evitare le lame di luce nel caso in cui la tenda abbia funzione oscurante. Stecche di rinforzo orizzontale in acciaio zincato Ø 4,5 mm inserite in apposite tasche saldate nel telo ogni 90 cm circa per evitare la fuoriuscita del telo

Fondale: FG42 piatto corredato di tappi scorrevoli laterali.

A supplemento profilo aggiuntivo di irrigidimento FG42R.

Per tende di grandi dimensioni (L oltre 4 m) FG42R obbligatorio e compreso nel prezzo

Manovra: a motore tubolare monofase 230V/50Hz M50, con fine corsa meccanico e cavo di alimentazione, protezione termina, indice di protezione agli spruzzi d'acqua IP44

Fissaggio: frontale, laterale o a soffitto. A supplemento guide autoportanti o fissaggio laterale del cassonetto

CHARACTERISTICS:

Application: vertical

Installation: outdoors/indoors

Headbox: C105/CT105 extruded aluminum headbox with removable cover and powder coated aluminum end cheeks. For supplement end cheeks that permit the box to be fitted directly to the side channels or end cheeks for side mounting

Roller tube: Ø 60 mm extruded aluminum tube or Ø 78 mm galvanized steel tube with slot to facilitate fabric removal

Side channels: G80 extruded aluminum side channels with incorporated brush to reduce light infiltration. The fabric is retained inside the side channels with the use of Ø 4.5 mm steel reinforcement rods inserted in horizontal pockets in the fabric, roughly one every 90 cm

Hem bar: FG42 extruded aluminum flat bottom rail with PVC end caps. FG42R extra reinforcement bar on supplement. FG42R compulsory and included in the price for widths greater than 4 m

Operation: motorised operation; 230V/50Hz tubular motor, with top/bottom limit switches and mains cable, thermal cut-out and class IP44 water resistance

Mounting: ceiling, wall or mounting in recess. For supplement box self supporting on side channels or side mounting of the headbox

note - notes

la tenda viene fornita senza interruttore

blind supplied without switch

tenda L > 400 cm motore 20 Nm - 20Nm motor for widths > 400

colori standard - standard colours

bianco Ral 9010 - white Ral 9010

nero Ral 9005 opaco - matt black Ral 9005

argento anodizzato - silver anodised

tessuti abbinabili - suitable fabrics

per l'utilizzo dei tessuti consultare la sezione dei teli confezionati e/o Tabella "A"

for fabric choice consult the fabric section and Tab. "A"

supplementi - supplement

